

Comparison between Known Adaptive Algorithms for Pre-FFT Beamforming in OFDMA Systems

Francisco C. J. Ribeiro, Igor R. Gomes, Bruno S. L. Castro and Gervasio P. S. Cavalcante

*Federal University of Para (UFPA)
01 Augusto Correa st., Belem, Para, Brazil
{carlosrj, ruiz, bruno, gervasio}@ufpa.br*

Abstract— This paper presents a study of applicability on using smart array systems on a generic multiuser OFDMA system. In this research, three well-known adaptive algorithms such as LMS, SMI and RLS are employed in Pre-FFT scheme, and their performances are evaluated in terms of speed of convergence, beamforming and null steering capabilities, and analysis of BER over a multipath fading channel. Good results on multiuser recovering by using spectral and spatial multiplexing demonstrate the reliability on combining OFDMA and adaptive arrays as a way to enhance the system capacity.

I. INTRODUCTION

Orthogonal-Frequency Division Multiplexing (OFDM) has received considerable attention from researchers in the last years. In this multicarrier modulation technique, a serial data bitstream is converted into several blocks of data to be transmitted in different, parallel and orthogonal subcarriers, subdividing the available bandwidth into narrowband subchannels. Broadband wireless systems such as IEEE 802.11 (Wi-Fi) and 802.16d (Fixed WiMAX) have adopted OFDM because of its notable advances on interference mitigating capabilities, robustness over frequency-selective channels and simplicity of implementation.

In turn, Orthogonal-Frequency Division Multiple Access (OFDMA) is a multiple access scheme based on OFDM principles, which divides the total number of subcarriers into several subchannels for allocation to multiple users on a same timeslot. OFDMA maintain the same benefits of OFDM and guarantees major scalability and MIMO compatibilities. For that reason, this protocol has offered superior performance compared to traditional multiple access methods such as TDMA and CDMA [1], and is expected to incorporate the next generation cellular systems (4G).

Additionally, spatial filtering using smart array systems has been well applied in cellular systems in the last years to overcome the problem of limited bandwidth by promoting Spatial Division Multiple Access (SDMA) [2]. Therefore, it is important to expand the investigation of spatial multiplexing to the new OFDMA-based systems in order to increase the spectral efficiency and to promote interference suppression, principally in multipath channels.

For the particular case of OFDM, spatial filtering has been studied in time and frequency-domain. The first scheme is called Pre-FFT beamforming because is implemented before the Fast Fourier Transform (FFT) block on reception, whereas the second is called Post-FFT beamforming because is performed after the FFT operation. The latter processes one

set of weights to each subcarrier separately, and its superior performance over the former is offered at cost of a much higher computational complexity due the need of one FFT operator on each array element. On the other hand, the Pre-FFT beamformer is performed over the whole signal, requiring only one set of weights and one FFT operator. In spite of its relative simplicity, the Pre-FFT scheme offers good results in most applications [3].

Thus, this work aims to employ, simultaneously, spectral (OFDMA) and spatial (SDMA) signal processing by implementing well-known adaptive beamforming algorithms in Pre-FFT scheme. A comparison between the LMS, SMI and RLS algorithms is made in terms of speed of convergence, beamforming and null steering capabilities, and analysis of BER over a multipath fading channel.

The remainder of this paper is organized as follows: Section II briefly describes the OFDMA system model as well as the Pre-FFT scheme used in this work. Mathematical descriptions of LMS, SMI and RLS algorithms are developed in Section III. Simulation results and analysis are presented on Section IV. Finally, Section V concludes the paper.

II. SYSTEM MODEL

A. Orthogonal-Frequency Division Multiple Access

The basic diagram of a wireless OFDMA transmitter at user terminal is showed in Fig. 1. This system uses a total of N subcarriers for parallel transmission. A serial-to-parallel (S/P) block groups the complex symbols to be fed into the Inverse FFT (IFFT) processor, and a subcarrier allocation algorithm choose which subcarriers will be used by placing the symbols only on its corresponding lines, whereas zeros are put on lines correspondent to subcarriers reserved to the other users [4].

Subsequent subcarrier modulation performed by IFFT operation can be mathematically expressed as

$$s[m] = \sum_{n=0}^{N-1} S[n] \exp\left(j \frac{2\pi mn}{N}\right), 0 \leq m \leq N-1, \quad (1)$$

where $S[n]$ is the data symbol (or zero) transmitted on n -th subcarrier, and $s[m]$ is a N -sample OFDMA symbol.

Additionally, a guard interval (GI) is attached to the beginning of the OFDMA symbol to avoid ISI as the duration of GI is longer than the delay spread of the channel [5]. The resulting symbol is then up-converted and transmitted.

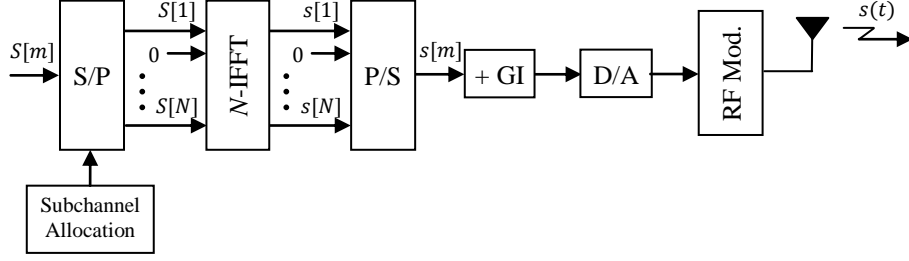

Fig. 1 Scheme of OFDMA transmission at a user terminal

B. Uniform Linear Array and Signal Modelling

Fig. 2 shows the scheme of a basic OFDMA receiver employing a K -element Uniform Linear Array (ULA) at base station. Considering that many users transmit from several directions in a multipath fading channel, a $K \times 1$ vector containing the passband signals received by each array element can be modelled as

$$x(t) = \sum_{d=1}^D \sum_{l=0}^{L_d} \alpha_{l,d} a(\theta_{l,d}) s_d(t) + n(t), \quad (2)$$

where

D : number of different directions of arrival (DOA);

$s_d(t)$: signal arriving from d -th direction;

L_d : number of multipath components of the signal arriving from d -th direction (excluding the direct component);

$\alpha_{l,d}$: complex amplitude of l -th multipath component on d -th direction;

$\theta_{l,d}$: DOA of l -th multipath component on d -th direction;

$a(\theta_{l,d})$: $K \times 1$ array response vector associated to $\theta_{l,d}$;

$n(t)$: $K \times 1$ Gaussian noise vector.

The following signal detection process includes: down-conversion on each array element, spatial processing, GI removal, subcarrier demodulation by a FFT processor, one-tap equalization and subchannel recovering for each user allocated on the system.

It should be noted that, in absence of a smart array system, at most U users, corresponding to the number of available subchannels, could access the mobile service at same time. Instead, spatial filtering multiplies the system capacity since

all U subchannels can be allocated on each DOA of interest, depending on the number of simultaneous and independent radiation beams generated by ULA.

C. Pre-FFT Beamforming

As shown in Fig. 2, a Pre-FFT beamformer was employed as spatial processing on reception. In this method, the array weighting is applied over the whole signal in time domain, that is, before FFT operation. The baseband sampled signal at the output of the Pre-FFT beamformer is obtained by a linear combination of the components directly detected by the K elements, according to the scheme showed in Fig. 3.

The array weighting process in Pre-FFT scheme can be expressed, in vectorial notation, as follows:

$$y[m] = w^H x[m], \quad (3)$$

where $(\cdot)^H$ denotes conjugate transpose and w is the $K \times 1$ complex weight vector.

According to eq. (3), if weights are perfectly adjusted, only signals arriving from desired directions will be available at output, which corresponds to steer radiation beams and nulls across the array azimuth. In fact, the array factor can be obtained as a function of w by the following equation:

$$A_F(\theta) = \sum_{k=1}^K w[k] \exp\left(j \frac{2\pi}{\lambda} (k-1)d \sin \theta\right), \quad (4)$$

where λ is the wavelength of the RF carrier, d is the element spacing and $\theta \in [0, 2\pi]$.

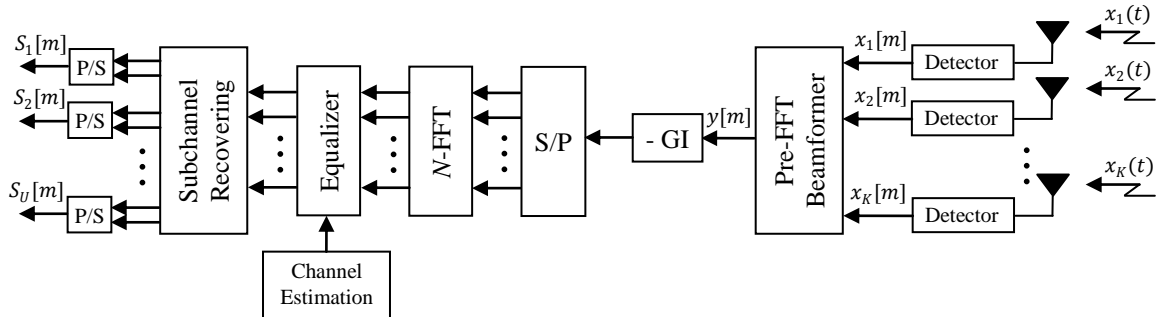

Fig. 2 Scheme of OFDMA reception with smart array system at a base station

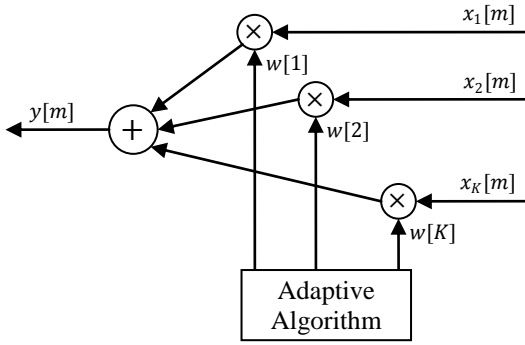

Fig. 3 Scheme of a Pre-FFT beamformer

III. ADAPTIVE ALGORITHMS

In a mobile system, weight adjustment must be adaptive to deal with a time-variant channel and to follow any changing on DOA of the users [6]. It is possible to find the optimal weights continuously by using adaptive algorithms, which employ a specific optimization criterion on every iteration.

The Minimum Mean Square Error (MMSE) is a commonly used criterion that minimizes the mean square error between the output $y[m]$ and the desired signal $d[m]$. Mathematically, it can be expressed by the following cost function:

$$J(w) = E[|d[m] - y[m]|^2], \quad (5)$$

where $E[\cdot]$ denotes the expected value operator.

A. Least Mean Squares (LMS) Algorithm

The LMS algorithm is a MMSE-based process which employs the steepest descent method for weight updating. According this method, successive weight adjustments are made in the opposite direction of the gradient of $J(w)$, leading to the optimum solution [7].

This approach can be obtained by the final equation

$$w[m+1] = w[m] + \mu x[m]e^*[m], \quad (6)$$

where $(\cdot)^*$ denotes complex conjugate, the step size μ controls the speed of convergence and the error signal $e[m]$ is given by

$$e[m] = d[m] - y[m] \quad (7)$$

The LMS algorithm is commonly used because of its simplicity and low computational costs, since it requires only $2W$ complex multiplications per iteration, where W is the number of weights [8].

B. Sample Matrix Inversion (SMI) Algorithm

The minimum value of eq. (5) is obtained for the optimum Wiener solution w_0 , given by

$$w_0 = R^{-1}\rho, \quad (8)$$

where R is the correlation matrix of $x[m]$ and ρ is the cross-correlation vector between $x[m]$ and $d[m]$.

Since R and ρ data are usually not available on reception, the SMI algorithm employs a time average estimate of R and ρ by using a block of input data samples detected within an observation interval [6], that is,

$$\hat{R} = \frac{1}{M} \sum_{m=M_1}^{M_2} x[m]x^H[m] \quad (9)$$

$$\hat{\rho} = \frac{1}{M} \sum_{m=M_1}^{M_2} x[m]d^*[m], \quad (10)$$

where $M = M_2 - M_1$ is the observation interval. The estimates \hat{R} and $\hat{\rho}$ are then applied to eq. (8) for weight calculation.

The SMI algorithm requires $3.5W^2 + W$ complex multiplications per iteration, more than that required by LMS. However, it offers a good approximation for optimum Wiener solution since the value of M is ensured to be at least twice the number of array elements [8].

C. Recursive Least Squares (RLS) Algorithm

The RLS algorithm can be viewed as a junction of LMS and SMI schemes since it still estimates the values of R and ρ , but in a iterative way. In other words, such estimates are made as a function of the current and several previous time samples [6]. Thus, estimates of R and ρ are now given by the following equations:

$$\hat{R}(m) = \sum_{j=1}^m \alpha^{m-j} x[j]x^H[j] \quad (11)$$

$$\hat{\rho}(m) = \sum_{j=1}^m \alpha^{m-j} x[j]d^H[j] \quad (12)$$

The additional term α in eqs. (11) and (12) is known as forgetting factor, whose function is to deemphasize very old time samples. Based on those new estimates, the RLS approach for optimal weights is obtained as

$$w[m] = w[m-1] + g[m]\xi^*[m], \quad (13)$$

where the a priori estimation error $\xi[m]$ and the gain vector $g[m]$ are defined as

$$\xi[m] = d[m] - w^H[m-1]x[m] \quad (14)$$

$$g[m] = \hat{R}^{-1}[m]x[m] \quad (15)$$

It should be noted that the RLS algorithm directly depends on the correlation matrix R . It also represents the most complex algorithm among the three studied since it requires $4W^2 + W + 2$ complex multiplication per iteration [8].

IV. SIMULATION RESULTS

The scenario simulated for this work was based on a 4-subchannel OFDMA system with 128 subcarriers, 32 allocated for each subchannel. The total bandwidth used was 1,25 MHz and 16-QAM modulation was applied.

In order to evaluate SDMA working simultaneously with OFDMA, 20 users were divided into 5 groups, each of them arriving at a 10-element ULA from the following directions of arrival: -20° and 30° (desired groups), -50° , 0° and 60° (interfering groups). Users on a same group were allocated on different subchannels.

For channel modelling, each group of signals sent 602 OFDMA symbols (1 for spatial weight adjustment, 1 for channel estimation and 600 for data) through a different 3-path Rician fading channel with K-factor equals to 1 and secondary multipath components 6 dB and 9 dB lower than the main component. SNR and SIR values were 20 dB e 0 dB, respectively. For adaptive spatial filtering, LMS, SMI and RLS algorithms were used with the following adjustment parameters:

- μ for LMS: $1/4\lambda_{max}$, where λ_{max} is the maximum eigenvalue of the instantaneous estimate of R ;
- M for SMI: 32 samples;
- α for RLS: 0.9999.

Fig. 4, 5 and 6 show the error signal obtained for the algorithms under study. It can be noted that LMS, in spite of its simplicity, offers the lower convergence speed, whereas SMI converges almost instantly (initial error on about 10^{-6}), indicating a good solution for high speed requirements.

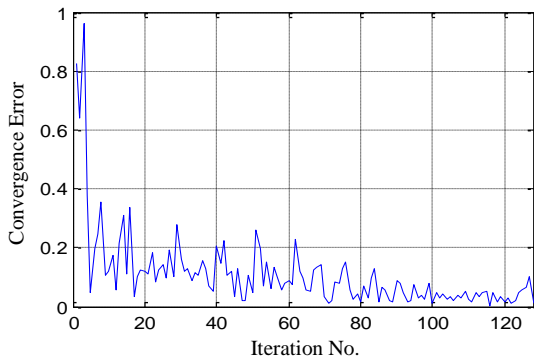

Fig. 4 Error signal for LMS algorithm

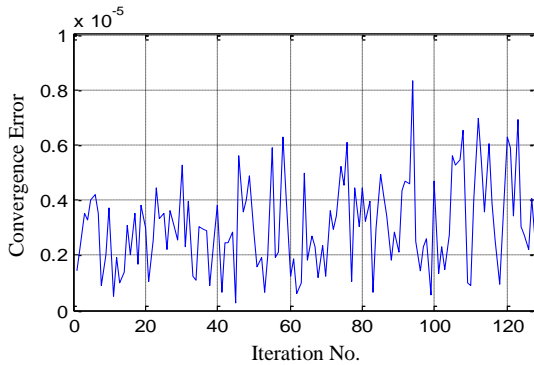

Fig. 5 Error signal for SMI algorithm

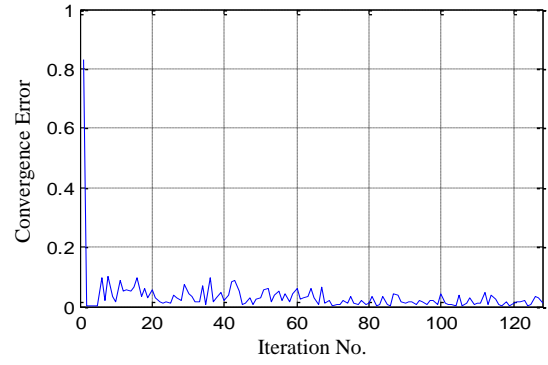

Fig. 6 Error signal for RLS algorithm

In Fig. 7, 8 and 9 the radiation patterns obtained by the algorithms under study are presented. By results, the three algorithms are capable to steer beams correctly on desired directions (-20° and 30°). However, in LMS the nulls are positioned on directions slightly shifted from interfering users. On the other hand, null steering in SMI and RLS approaches work well, but in SMI deeper nulls are obtained.

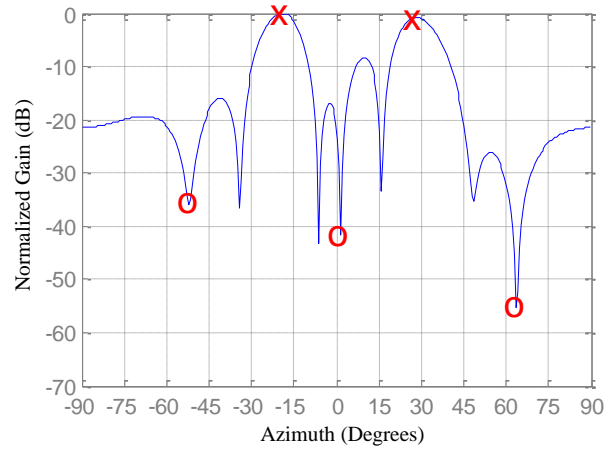

Fig. 7 Array factor obtained for LMS algorithm

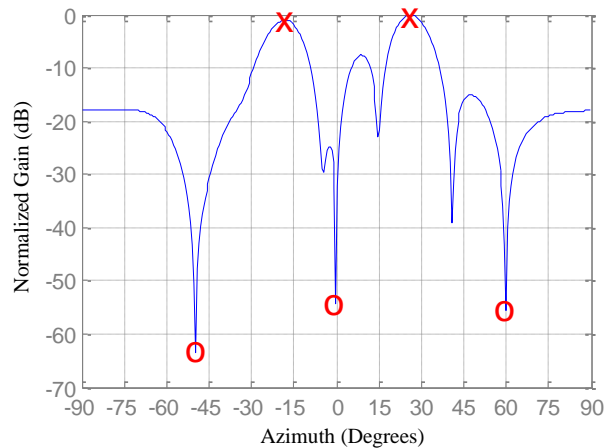

Fig. 8 Array factor obtained for SMI algorithm

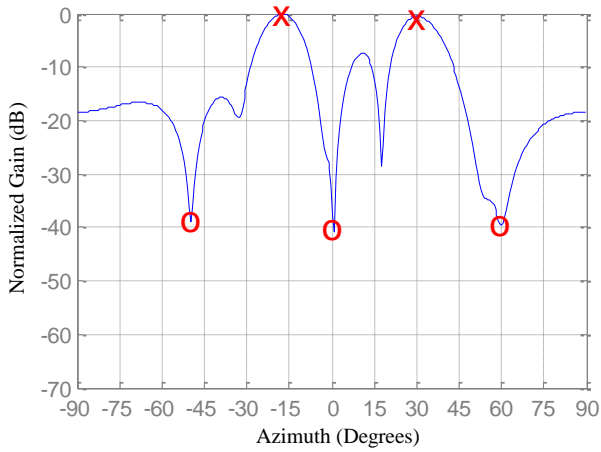

Fig. 9 Array factor obtained for RLS algorithm

Fig. 10 shows a comparison of BER vs. SNR among the three adaptive algorithms studied. These values of BER were obtained as a mean of the BER values of each recovered signal since there were 4 signals on each DOA of interest. As expected from previous results, LMS algorithm offers the worst performance, whereas using RLS and SMI method can lead to a considerable performance gain on reception.

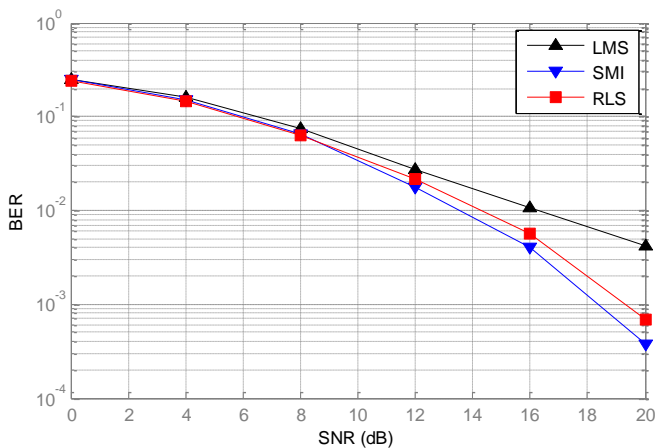

Fig. 10 – BER vs. SNR results for LMS, SMI and RLS algorithms

V. CONCLUSIONS

This paper aimed to provide a study of reliability on using spatial filtering to enhance the capacity of OFDMA systems. It could be noted by results that the final performance of each adaptive algorithm is directly related to its convergence speed within the training interval. Since this period does not correspond to usable data samples, it is important that the algorithm used requires as minimum training interval as possible in order to minimize the system overhead.

On the other hand, it is also necessary to establish a compromise between good performance and low computational costs. The SMI algorithm, for example, offers the best performance and the maximum speed of convergence but at a cost of a very high complexity compared to the other adaptive approaches such as LMS and RLS.

Finally, results demonstrated that spatial filtering can effectively improve the capacity of the system. In fact, in a simulated 4-subchannel OFDMA system, a total of 8 signals were successfully received at same time by allocating all available subchannels in 2 different DOA of interest. This indicates a spectral efficiency gain since more users could access the service without any improvement on the system bandwidth.

ACKNOWLEDGMENT

This work was supported by CNPq under covenant 573939/2008-0 (INCT-CSF) and FAPESPA / UFPA / FADESP / SEDECT, N°. 067/2008.

REFERENCES

- [1] H. Yin and S. Alamouti, "OFDMA: a broadband wireless access technology", in *Proc. IEEE Sarnoff Symposium*, 2006, p. 1-4.
- [2] L. C. Godara, "Applications of antenna arrays to mobile communications, part I: performance improvement, feasibility, and system considerations", *Proceedings of the IEEE*, vol. 85, n. 7, pp. 1031-1060, Jul. 1997.
- [3] D. Borio, L. Camoriano and L.L. Presti, "Wiener solution for OFDM pre and post-fft beamforming", in *European Signal Processing Conference*, 2006.
- [4] S. Hou and C. C. Ko, "Intercarrier interference suppression for OFDMA uplink in time- and frequency-selective fading channels", *IEEE Transactions on Vehicular Technology*, vol. 58, n. 6, pp. 2741-2754, Jul. 2009.
- [5] R. Prasad, *OFDM for wireless communications systems*, Boston, United States: Artech House, 2004.
- [6] F. B. Gross, *Smart antennas for wireless communications*, Virginia, United States: McGraw-Hill, 2005.
- [7] L. C. Godara, "Applications of antenna arrays to mobile communications, part II: beam-forming and direction-of-arrival considerations", *Proceedings of the IEEE*, vol. 85, n. 8, pp. 1195-1245, Aug. 1997.
- [8] B. P. Cheung, "Simulation of adaptive array algorithms for OFDM and adaptive vector OFDM systems", M. Eng. thesis, Virginia Polytechnic Institute and State University, Virginia, United States, Sep. 2002.